

Precision Storage Vessels

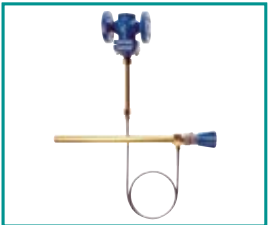

Indirect Heated Water Heaters

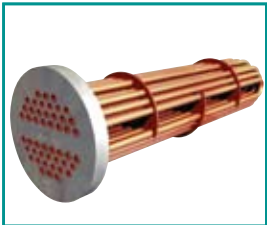

PRECISION



High Capacity Indirect Heated Storage Calorifiers

Indirect Heated Storage calorifiers are one of the easiest method of generating hot water for both domestic and industrial applications. Storage calorifiers are installed in hospitals, hotels, sports centers and general residential buildings. PRECISION Calorifiers can be used in sites where a dedicated plant producing steam for laundry or hot water boiler is available.

Storage Calorifier

Storage calorifiers are sized to meet the peak demand period with recovery periods varying from one to four hours.

Advantages

- Electric power is not required, hence no big investments in Transformer etc.
- Heating coil duty is high.
- No frequent shutdown due to short circuit etc.
- No need of higher inventory electric spares.

Standards

ASME Code construction:- All tanks are constructed in accordance with ASME code section IV Stamped and labelled for 125 PSI (8.6 BAR) Standard.

Precision also design High Capacity Water Heaters / Calorifiers as per British Standard BS 853:1996 or BS 5500:1997 or in accordance with Art 3.3 of the European Directive EEC/97/23 for pressure equipment.

HW	I	Thermal Duty	GL	V	1000 L
Hot Water	Indirect	KW	Shell Material	Configuration	Capacity
		Input	GL-Glass Lined PC-Precision Coat	V-Vertical H-Horizontal	Litres

Eg: HWI 50 PCV 1000L



Vessel Lining

Precision Coat

Precision coat is a polymerized coating which is applied to all internal surfaces of the tank. Tank surfaces are first sandblasted and cleaned to a white metal finish and then precision coat is applied uniformly. The tank is then forced cured at 95°C to form a glossy lining unaffected by thermal shock from -6°C to 100°C. Precision coat is approved by US department of agriculture and with NSF/61 certification for drinking water.

Standard - Shells

Steel SA516 Gr-70
Coating FDA approved Precision coat material



Glass Lining

Precision's glass lining is a specially formulated vitreous porcelain enamel, which is applied to all interior surfaces of the tank. Tank surfaces are first sandblasted to a white metal finish and then Porcelain enamel is applied uniformly. The tank is then fired to 900°C in a furnace to achieve 100% molecular fusing of the glass to the interior steel surface, which forms a best possible glass coating for potable water in a strong vessel.

Standard - Shells

Steel SA516 Gr-70
Glass FDA approved vitreous porcelain enamel



Heating Coils

(Internal Heat Exchanger)

For steam and condensate the battery is a simple 2-pass U-tube battery.

Heater batteries are constructed from finned tube. This extended surface reduces the overall size of the battery. Plain tube can be supplied and should be specified at the enquiry or order stage so that provision is made for fitting the larger battery. Plain tube will be recommended when the operating conditions are known to make it advisable.

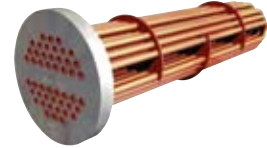

Heating Medium - Primary Heating Systems

Steam

Steam is an ideal medium for water heating. Tubular heat exchangers can be designed to accommodate a wide range of pressures. Standard engineering practice is to use 2 - 4 bar g steam pressure to have better work done based on Thermodynamic principle.

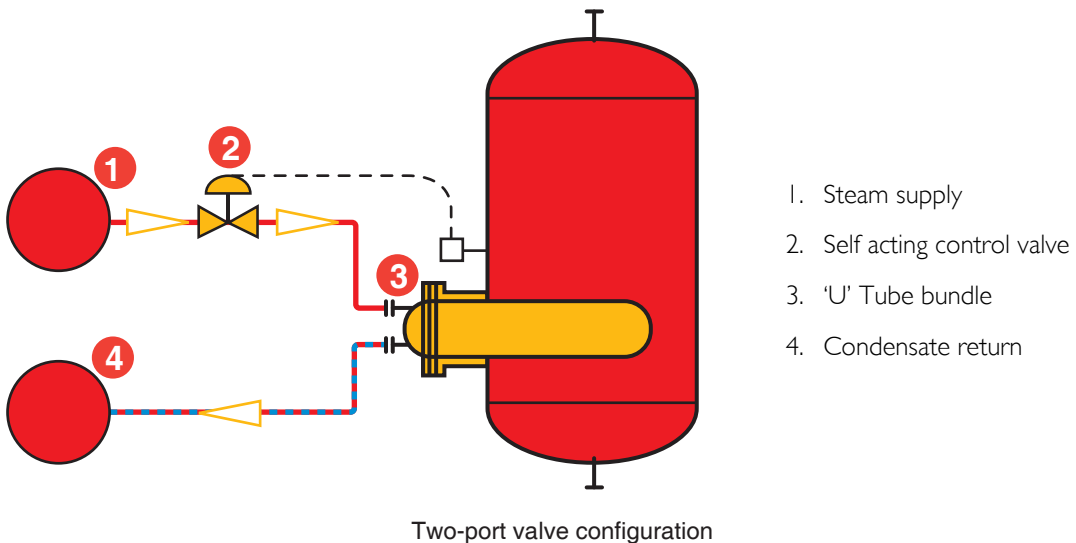

Heating Medium - High Temperature Hot Water

HTHW (maximum temperature of 100°C)

High temperature hot water is one of the most common means of heating. Flows are usually based on a temperature drop of 11°C (from 82-71°C). Primary working pressure to be greater than the shell design pressure. The calorifier will be fitted with a safety valve in accordance with the requirements of BS / ASME Standards.



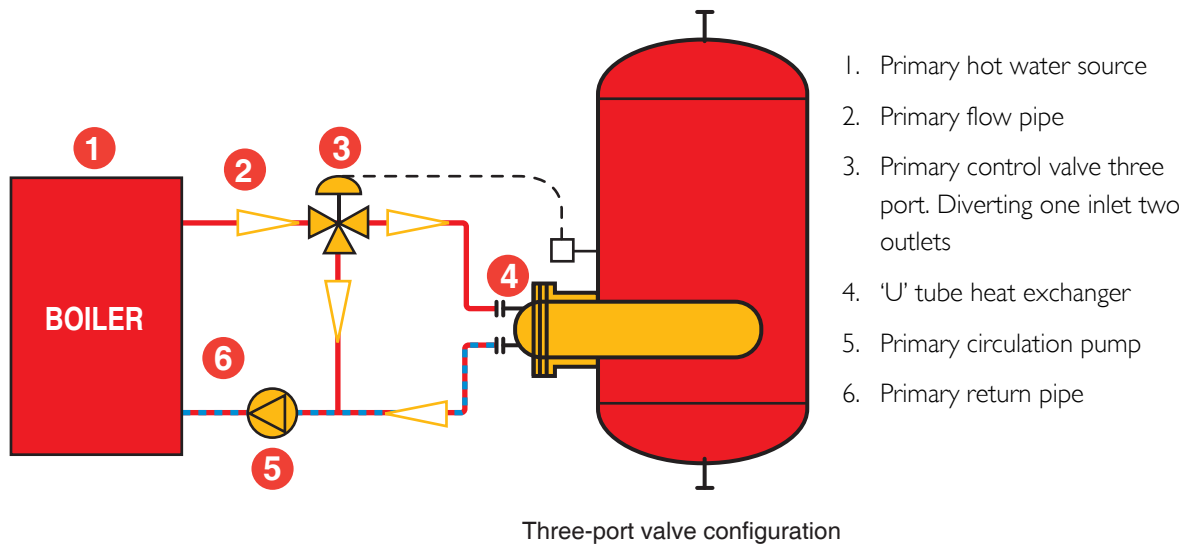

Chilled Water

Chilled water can also be used in the tubular heat exchanger to cool domestic water from any desired temperatures.

Specifying Indirect Heated Storage Calorifiers

High capacity water heaters shall be model ----- with ----- litre storage capacity rated at -----litres and with thermal duty ----- kW. Heaters are to be insulated and jacketed for vertical installations. The water heater tank shall be constructed in accordance with ASME Boiler and pressure vessel code requirements stamped and registered with the national Board of Boilers and Pressure vessel inspectors. The tank shall have 125 Psi (8.6 bar) working pressure as standard. For others please specify.

The tube heating element shall be constructed and stamped according to section VIII of ASME code. The tubes bundles shall be constructed of $\frac{3}{4}$: OD 20 GA, deoxidized drawn copper tubing. The heating coils shall be installed in the tank by bolted connection to the collar flange and tube head. The water to water generator shall be equipped with an isolation valve, direct sense self actuated temperature control valve, tank temperature sensor and an inlet Y stainer. A jacket mounted temperature and pressure gauge shall be provided. Primary temperatures supplied will be either High temperature water @ 90 °C and the return temperature to be 80 °C or in case of steam the primary steam pressure to be 2 - 4 barg.

The storage tanks shall be supplied with a ASME temperature and pressure relief valve.

The interior of the storage tank shall be glass lined and fired to 900 °C to ensure a molecular fusing of glass and steel or precision coat and furnished with magnesium anodes to provide protection against corrosion.

The storage tank shall be furnished with a factory installed heavy steel jacket finished with a baked acrylic enamel finish. The storage tanks shall be completely encased in 2" thick fibre glass or rockwool insulation to meet the energy efficiency requirements of the ASHRAE standards. The tank shall be supplied with lifting lugs.

Secondary connections shall be screwed to BS 21 or flanged to BS 4504 or equivalent ASTM Standards with following connections:-Secondary flow outlet, Secondary return inlet, Cold feed inlet. Each tank shall be furnished with magnesium anodes to protect tanks against corrosion. The tank shall be fitted with screwed connection for safety valve, thermostats, Pressure gauge.

Selection & Sizing

Maximum Demand Rates (litres/hour) @60°C

Sl. No.	Description	Apart ment house	Club	Gymnasium	Hospital	Hotel	industrial Pant	Office Building	Private Residence	School	YMCA
1	Basin, Private Lavatory	7.6	7.6	7.6	7.6	7.6	7.6	7.6	7.6	7.6	7.6
2	Basin, Public Lavatory	15	23	30	23	30	45.5	23	-	57	30
3	Bathtub	76	76	114	76	76	-	-	76	-	114
4	Dishwasher	57	190-570	-	190-570	190-760	76-380	-	57	76-380	76-380
5	Foot basin	11	11	46	11	11	46	-	11	11	46
6	Kitchen sink	38	76	-	76	114	76	76	38	76	76
7	Laundry, Stationary tub	76	106	-	106	106	-	-	76	-	106
8	Pandry sink	19	38	-	38	38	-	38	19	38	38
9	Shower	114	568	850	284	284	850	114	114	850	850
10	Service sink	76	76	-	76	114	76	76	57	76	76
11	Hydrotherapeutic shower				1520						
12	Hubbard bath				2270						
13	Leg bath				380						
14	Arm bath				130						
15	Sitz bath				114						
16	Continuous flow bath				625						
17	Circular wash sink				76	76	114	76		114	
18	Semicircular wash sink				38	38	57	38		57	
	Demand Factor	0.3	0.3	0.4	0.25	0.25	0.4	0.3	0.3	0.4	0.4
	Storage Factor	1.25	0.9	1	0.6	0.8	1	2	0.7	1	1

Courtesy: Ashrae

Example:- Determine heater and storage tank size for an apartment building from a number of fixtures.

Solution

60 Lavatories	x	7.6	l/h	=	456 l/h
30 Bathtubs	x	76	l/h	=	2280 l/h
30 Showers	x	114	l/h	=	3420 l/h
60 Kitchen sinks	x	38	l/h	=	2280 l/h
15 Laundry tubs	x	76	l/h	=	1140 l/h
Possible maximum demand				=	9776 l/h
Proable Maximum demand	=	9576 x 0.30		=	2873 l/h
Heater or coil capacity				=	2873 l/h
Storage tank capacity	=	2873 x 1.25		=	3591 l/h

Storage Calorifiers

★ Standard Cradle/leg height 150mm

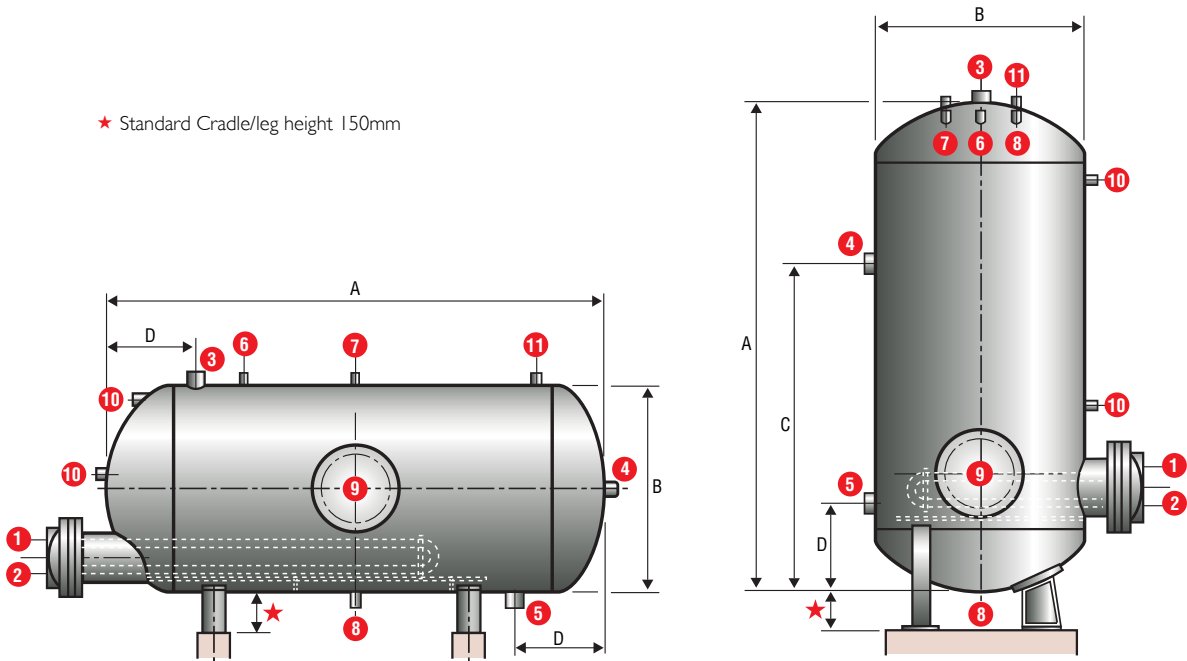

Standard Connections

- | | | |
|-----------------------------|----------------|--|
| 1 Primary Flow Steam | 5 Cold Feed | 9 Manhole |
| 2 Primary Return Condensate | 6 Thermometer | 10 Thermostat x 2 |
| 3 Secondary Flow | 7 Safety Valve | 11 Anti-Vacuum Valve |
| 4 Secondary Return | 8 Drain | ★ Other connections available on request |

HWI DIMENSIONAL DATA

Model No.	Capacity Litres	Dimensions in mm				Connections			Weights kgs
		A	B	C	D	in /Out	DRAIN	RETURN	
HWI 440	440	1800	600	1350	250	1¼"	1"	1¼"	250
HWI 550	550	1700	675	1150	300	1¼"	1"	1¼"	260
HWI 700	700	1750	750	1150	300	1¼"	1"	1¼"	300
HWI 800	800	1950	750	1300	300	1½"	1¼"	1½"	330
HWI 900	900	2000	800	1350	330	1½"	1¼"	1½"	400
HWI 1000	1000	1950	750	1300	330	2"	1¼"	2"	430
HWI 1200	1200	2100	900	1400	345	2"	1¼"	2"	480
HWI 1350	1350	2350	900	1550	345	2"	1¼"	2"	530
HWI 1500	1500	1950	1050	1300	395	2"	1¼"	2"	550
HWI 1800	1800	2300	1050	1550	395	2"	1¼"	2"	630
HWI 2000	2000	2500	1050	1650	395	2"	1¼"	2"	670
HWI 2300	2300	2400	1150	1600	410	2"	1¼"	2"	740
HWI 2500	2500	2450	1250	1650	430	2"	1¼"	2"	800
HWI 3000	3000	2900	1200	1950	430	2"	1½"	2"	910
HWI 3500	3500	2700	1350	1800	475	2"	1½"	2"	1250
HWI 4000	4000	3050	1350	2050	475	2"	1½"	2"	1370
HWI 4500	4500	3400	1350	2250	475	3"	1½"	3"	1500
HWI 5000	5000	3200	1450	2400	500	3"	1½"	3"	1500
HWI 6000	6000	3800	1450	2850	500	3"	1½"	3"	1720
HWI 7000	7000	3300	1680	2475	475	3"	1½"	3"	2350
HWI 8000	8000	3700	1680	2850	475	3"	1½"	3"	2560
HWI 9000	9000	4200	1680	3150	475	3"	1½"	3"	2820
HWI 10000	10000	4600	1680	3600	475	3"	1½"	3"	3030
HWI 12500	12500	6000	1830	3750	550	3"	1½"	3"	4360
HWI 15000	15000	6000	1830	4500	550	3"	1½"	3"	4360

* Pressures available upto 20 bar (300psi), * Capacities available upto 30,000 litres., * Specified weights are for 7 bar Design pressure & 10.5 bar Test Pressure., * Alternate sizes available., * Please consult Factory.



Accessories

Thermometer

The thermometer is located near the top of a storage calorifier to measure the temperature of water reaching the outlet.



Safety Valve

All indirect heated calorifiers should be fitted with a safety valve to protect the cylinder against over-pressure due to malfunction of controls or incorrect operation.

Supports

All indirect heated calorifiers have their legs or cradles permanently fixed to the shell before dispatch. This is to assist handling and to offer greater protection against damage.

Inspection Opening

The heater and shell internals can be inspected by withdrawing the heater. Alternatively upon request a manhole can be incorporated so that inspection does not disturb the heater or its connections.



Steam Traps

Steam traps combine high standards of performance and long life with economy for heating service where continuous drainage with high air-venting capacity is required. Because of the wide use of vacuum returns in systems of this type, the thermostatic air vent element is charged to give it the capability of compensated response to the pressure-temperature curve of steam at any pressure from less than 20" Hg vacuum to 30 psig gauge. Steam traps will vent air at slightly below steam temperature throughout this entire range of operation. These traps have inlet connections on both sides of the body to provide flexibility in piping.



Strainer

Strainer is of SG iron screwed Y-type. The standard stainless steel screen is 0.8mm perforations. As options, other perforations and mesh sizes are available as well as monel screens.



Anodes

Magnesium anodes are supplied as standard to water properties. Magnesium anodes help to protect cylinders. The life of the magnesium anode depends on the quality of the water and regular checks should be made to establish a service period.



CE

Anti-Vacuum Valve

All water heaters are supplied with anti vacuum valve as standard to protect the tank against partial vacuum.



Insulation

Adequate thermal insulation is essential to prevent unnecessary heat losses from storage calorifiers which may be standing for many hours at working temperature. Standard factory-fitted insulation consists of 50mm thick Fiber glass wool / rock wool mattress which is closely fitted to the shell and encased in galvanized iron steel sheets of 1mm thick with two coats of gloss paint.

Self Operated Temperature Regulators

Temperature regulators with globe or three-way valves and Control Thermostats are applicable for liquids, gases and steam or for coolants such as cooling water. The regulator consists of valve and Control Thermostat. The features of the valves are 1) flanges, 2) Balanced globe valve, 3) valve closes when the temperature rises, 4) Connections according to DIN and ANSI; 5) Body Materials – Cast Iron and Spheroidal graphite Iron.

Control Thermostats

Control Thermostats are applied for temperature regulation for heating or cooling installations. The control thermostats consists of a temperature sensor, a set point adjuster with temperature scale and excess temperature safety device, a capillary tube and an operating element. They regulate the temperature of the medium by causing the connected valve to open or close.



Safety Temperature limiter (STL)

STL is applied for temperature limitation in heating installations according to DIN standard. It interrupts and locks the energy supply when an adjusted limit value is reached, when the capillary tube breaks or when leakage occurs in the sensor system and also it can only be reset or started-up with a tool, provided the defect has been eliminated and the temperature has fallen below the limit value.

Pump Trap

Pump trap is the smallest non-electric solution that can move condensate or other liquids from lower to higher points and from lower to higher pressures. Condensate can be returned at temperatures above the limit of conventional electric centrifugal pumps without the headaches of leaking seals or cavitation problems.



Water Quality & Water Heating

All waters contain dissolved substances. A large proportion of these dissolved substances are generally calcium and magnesium carbonates and sulphates. The concentration of these salts in the water define the hardness of the water. Greater their concentration harder the water, smaller their concentration softer the water.

Generally, water which can be considered as slightly hard to moderately hard we must consider the effects on the lining and other components within the calorifier shell.

For more details please consult your water treatment SPECIALIST.

Useful Conversions

Electrical Data

$$\text{Amps (3 Phase)} = \frac{\text{kW} \times 1000}{\text{Volts} \times 1.732}$$

$$\text{Amps (1 Phase)} = \frac{\text{kW} \times 1000}{\text{Volts}}$$

Btu/hr Requirement

$$\begin{aligned} \text{Btu / hr Output} &= \text{GPM} \times 60 \text{ min/hr} \times 8.33 \text{ lb/gal} \times \text{Temp. Rise} \\ \text{Btu / hr Input} &= \frac{\text{GPM} \times 60 \text{ min/hr} \times 8.33 \text{ lb/gal} \times \text{Temp. Rise}}{\% \text{ Efficiency}} \end{aligned}$$

Efficiency of Heat Transfer

$$\% \text{ Efficiency} = \frac{\text{GPH} \times 8.33 \text{ lb/gal} \times \text{Temp. Rise}}{\text{Btu/hr Input}}$$

Recovery - Electric

$$\text{GPH} = \frac{\text{kW Input} \times 3412 \text{ Btu/kW} \times \% \text{ Efficiency}}{8.33 \text{ lb/gal} \times \text{Temp. Rise}}$$

Temperature Rise

$$\text{Temp. Rise} = \frac{\text{Btu/hr Input} \times \% \text{ Efficiency}}{\text{GPM} \times 60 \text{ min/hr} \times 8.33 \text{ lb/gal}}$$

Heat - Up Time

$$\text{Time in hours} = \frac{\text{GPH} \times 8.33 \text{ lb/gal} \times \text{Temp. Rise}}{\text{Btu/hr Input} \times \% \text{ Efficiency}}$$



RANGE OF PRODUCTS

- ✦ HEAT EXCHANGER PACKAGE
- ✦ AIR RECEIVER
- ✦ STEAM ACCUMULATORS
- ✦ INDIRECT HEATED STORAGE CALORIFIERS
- ✦ FEED TANKS & CONDENSATE RECEIVERS
- ✦ BLOWDOWN VESSEL
- ✦ ELECTRIC WATER HEATERS
- ✦ BUFFER VESSELS



PRECISION

Precision Storage Vessels Pvt. Ltd.

Kalpadi, P.O.
Kalpadi, K. K. Dist.
Tamil Nadu, India
Tel : 0091 4651 237730
Fax: 0091 4651 238585

www.precisionstoragevessels.com



PRECISION

Precision Storage Tanks LLP

3rd Floor 82 King Street
Manchester MZYWQ
United Kingdom
www.precisionstorage.co.uk

email: smanuel@eim.ae



EN ISO 9001: 2000